

# Mobil™ LubeGuardPro

## FLUID HANDLING

### OIL TRANSFER CONTAINER

The first best practice solution that fully isolates oil from the environment during transfer.



### APPLICATIONS

- Transferring small volumes of oil.
- Topping off reservoirs
- Small volume storage.

# Overview

## Key Benefits

- Isolates and protects oil to meet best practice standards with breathers and ISO B quick connects
- Provides variable flow control with trigger mechanism
- Square containers store 27% more volume per square foot than round containers
- Prevents cross contamination and provides easy lubricant identification with 11-color-coding options and tagging system
- Minimizes inventory management with modular, interchangeable spouts, collar rings, and pump caps as the only color-coded components

## Performance

Keeps oil clean and dry during storage and transfer to machinery with a maximum operating viscosity range of ISO VG 680 (3000ssu/648cSt) at 100°F/38°C within ambient temperature ranges of -40°F to 176°F (-40°C to 80°C).

### Available Options: Dispensing Lid

- Standard vent plug or desiccant and non-desiccant breathers
- Optional 1/2" ISO B plug for filling

### Spout options

- 5" or 8" rigid or 16" extended spout
- 5" rigid has a 1" tip opening
- 8" tip opening options are 1", 1/2", or 1/4"
- Eleven color options

### Pump Lid

- Standard vent plug or desiccant and non-desiccant breathers
- Optional 1/2" ISO B plug for filling
- Cap for storage or pump for transferring oil
- Eleven cap and pump ring color-coding options

### Container

- 1 Gallon/4 Liter, 1.8 Gallon/7 Liter, 2.6 Gallon/10 Liter sizes

## Wetted Materials & Components: Dispensing Lid and Spout

- Nylon
- 304 Stainless Steel
- Steel
- Buna-N
- HDPE
- PTFE

## Pump Lid, with Pump

- 304 Stainless Steel
- Steel
- Fluoro-silicone
- Silicone
- Nylon
- PVC
- Polyurethane
- Aluminum
- Vinyl
- HDPE

## Container

- HDPE

## Chemical Compatibility:

- Recommended for mineral-based industrial oils and most synthetic oils. HDPE containers will not chemically react with oil or additive packages.

### Spouts, pump caps, and pump rings come in 11 different colors for color-coding:

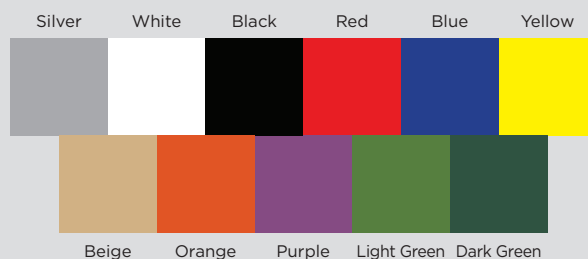

# Specifications

## By the Numbers:

### 1 Three Practical Container Sizes

Space saving square containers in three sizes – 1 gallon/4 liter, 1.8 gallon/7 liter, 2.6 gallon/10 liter

### 2 Dispensing and Pump Lids

Hex and ridge design for strength and an ergonomically designed handle for a firm grip on the dispensing lid

### 3 Trigger Mechanism

Precise pour control and locking mechanism for ease of use, and a specially designed spring and o-rings keep lubricants sealed until the trigger is engaged

### 4 Port for Optional Breather

Optional non-desiccant (DC-ND-2) or desiccant (DC-BB) breathers can be added to control moisture and contaminants, basic lid comes standard with a vent plug

### 5 ISO B Port

Optional 1/2" ISO B quick connect ports for best practices oil transfer to container

### 6 Interchangeable Spouts

Interchangeable spouts come in 5" or 8" rigid and 16" extended, three tip sizes, and 11 colors

### 7 Spout Cap

Spout cap prevents contamination of oil during storage and can be clipped onto the side of the spout during use

### 8 Pump Color-Coding Cap and Ring

Color-coding cap for lid and ring for pump come in 11 colors and offer a best practices color-coding solution

### 9 Pump

Heavy duty pump with D-ring down-stroke handle delivers 1 liter with approximately 12 strokes

### 10 Pump Hose

Pump hoses available in 5' or 10' lengths, and with a dispensing nozzle or 1/2" ISO B coupler

### 11 Lubricant Tagging System

2" X 3" color-coding labels with recommended color & pattern tagging system



# Dimensions

## DISPENSING LID:

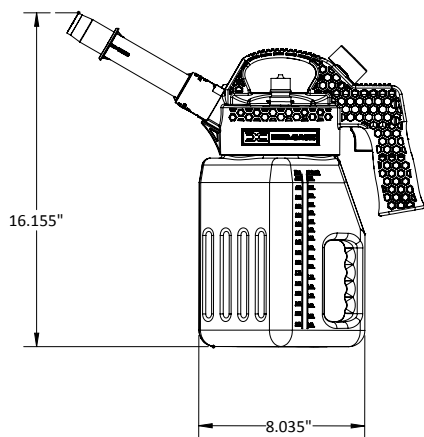

4 Liters

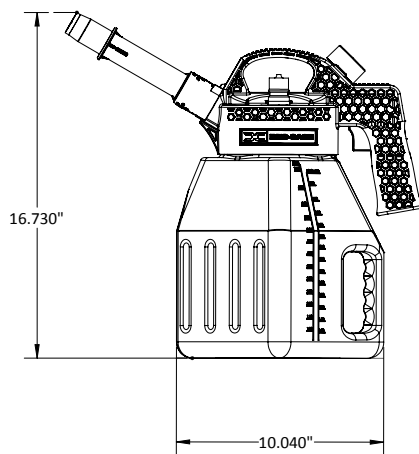

7 Liters

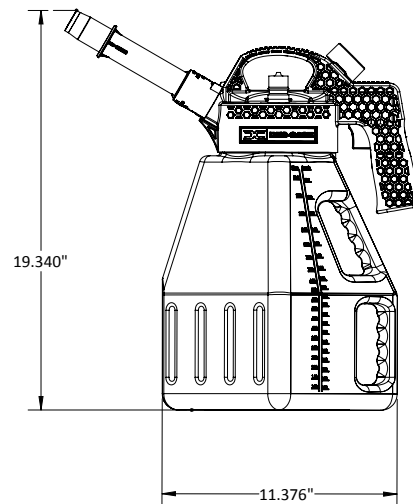

10 Liters

## PUMP LID:

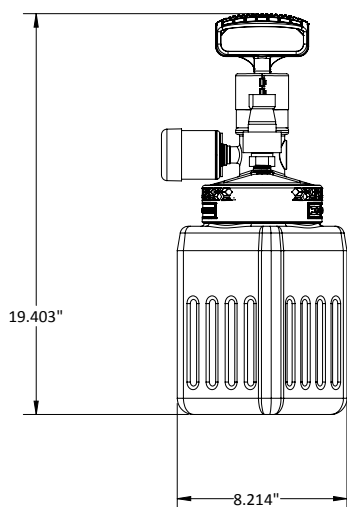

4 Liters

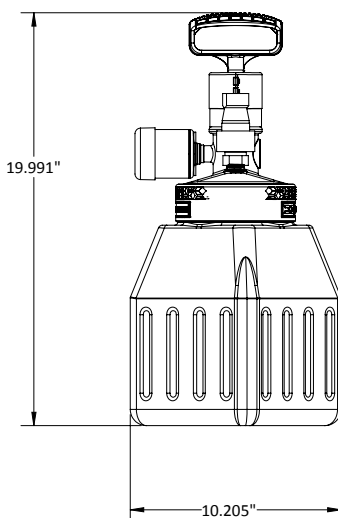

7 Liters

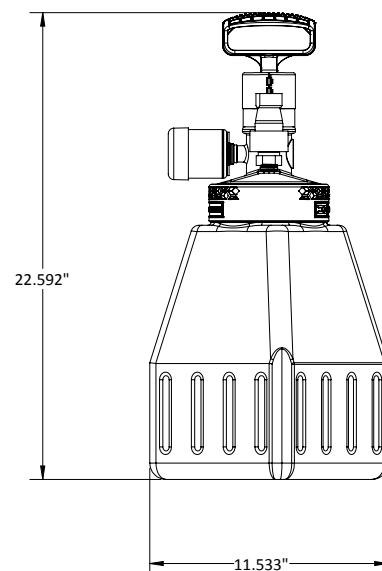

10 Liters