

Mobil™ LubeGuardPro

FLUID HANDLING

GEARBOX ADAPTER KIT

Easily connect your gearbox to your filtration system while keeping your lubricants and equipment clean and dry.



Overview

KEY BENEFITS

- Prohibits entry of dirt and moisture
- Allows for easy equipment adaptation and quick connection to a filtration system
- Allows for customization

Did You Know?

Pairing fluid handling filtration with breather protection, via a Mobil adapter kit, allows for maximum system integrity—requiring less equipment and labor while reducing system contamination.

Standard Features

- Replaceable breather with color-indicating desiccant
- Quick connect plugs
- Single-position vacuum indicator
- 3/4" male NPT connection size
- Customizable colors

Components

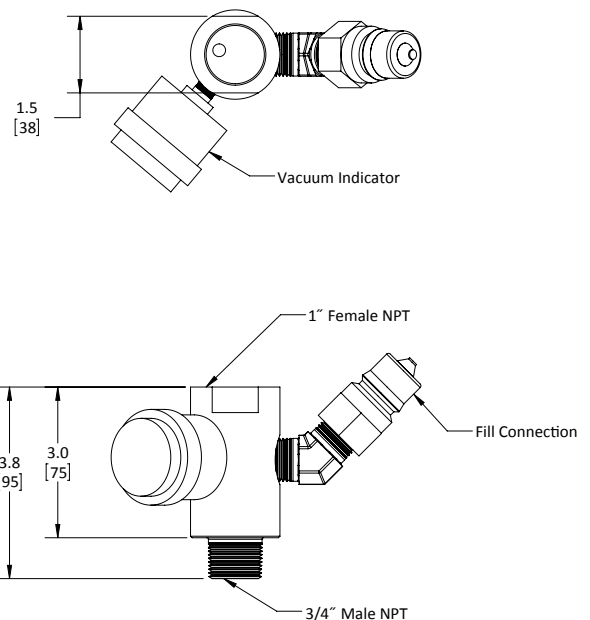

Try the Entire Selection of Mobil Adapter Kits



To Order:

GEARBOX ADAPTER KIT

MGA					
	Box 1	Box 2	Box 3	Box 4	Box 5

NOTE: Recommended maximum flow rate of 5gpm

Drain & Fill Connector Type [Box 1]

Code	Description
B	ISO B Connector
A	ISO A Connector
F	Flush Face Connector
R	ISO B Connector-BSPP
Q	ISO A Connector-BSPP
P	Flush Face Connector-BSPP

NOTE: All connectors are plug ends (male)

Fill Tube Length [Box 3]

Code	Description
02*	2 inches
04	4 inches
06	6 inches
08	8 inches
10	10 inches
12	12 inches

*Recommended length of 2"

Custom Colors [Box 5]

Code	Description
1	Brushed Aluminum
2*	Black
3	White
4	Blue
5	Red
6	Yellow

*Black is standard

Drain & Fill Sizing [Box 2]

Code	Description
1	Drain: 1" connection Fill: 3/4" connection
2	Drain: 3/4" connection Fill: 1/2" connection

NOTE: Units are built for optimum performance when using 1" (drain) and 3/4" (fill) connections. Decrease in performance may occur when selecting other size combinations.

Breather Filter† [Box 4]

Code	Description	
H8*	3-micron particulate desiccant hybrid breather; 0-400 gallons; 18.75gpm	[MOB-HG-8]
V2	3-micron particulate desiccant hybrid breather; 0-200 gallons; 18.75gpm	[MOB-VG-2]
V3	3-micron particulate desiccant hybrid breather; 201-350 gallons; 17.1gpm	[MOB-VG-3]
V4	3-micron particulate desiccant hybrid breather; 351-500 gallons; 13.5gpm	[MOB-VG-4]

*Standard for gearbox adapters

NOTE: For breather replacement, use bracketed part number.

†Considerations such as humidity level, frequency, and maximum amount of air flow, ambient temperatures, gallons of lubricant, and chemical compatibility are very important in sizing a desiccant breather properly. Call Mobil for assistance in sizing the appropriate breather for your application.